

AMBASSADOR VERTICAL DIVIDER

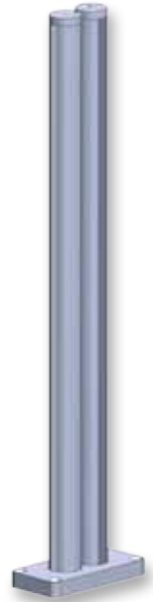

AB-8DV

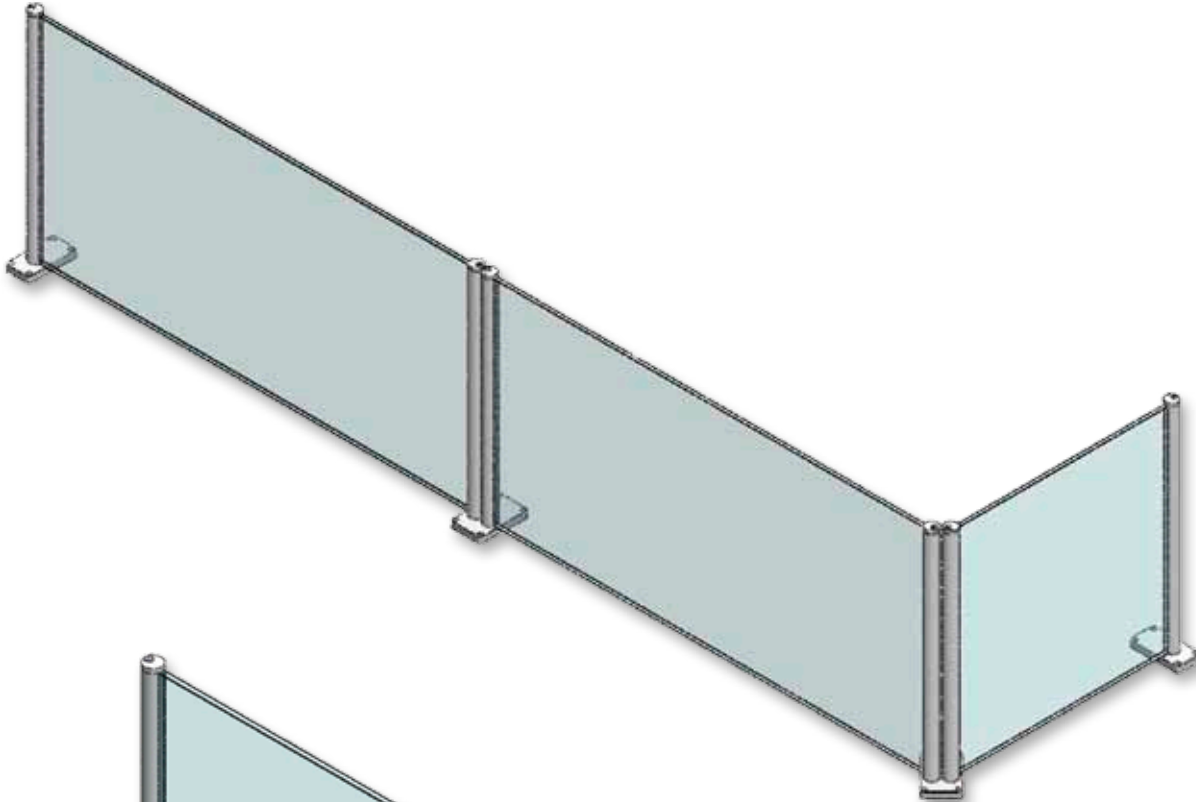
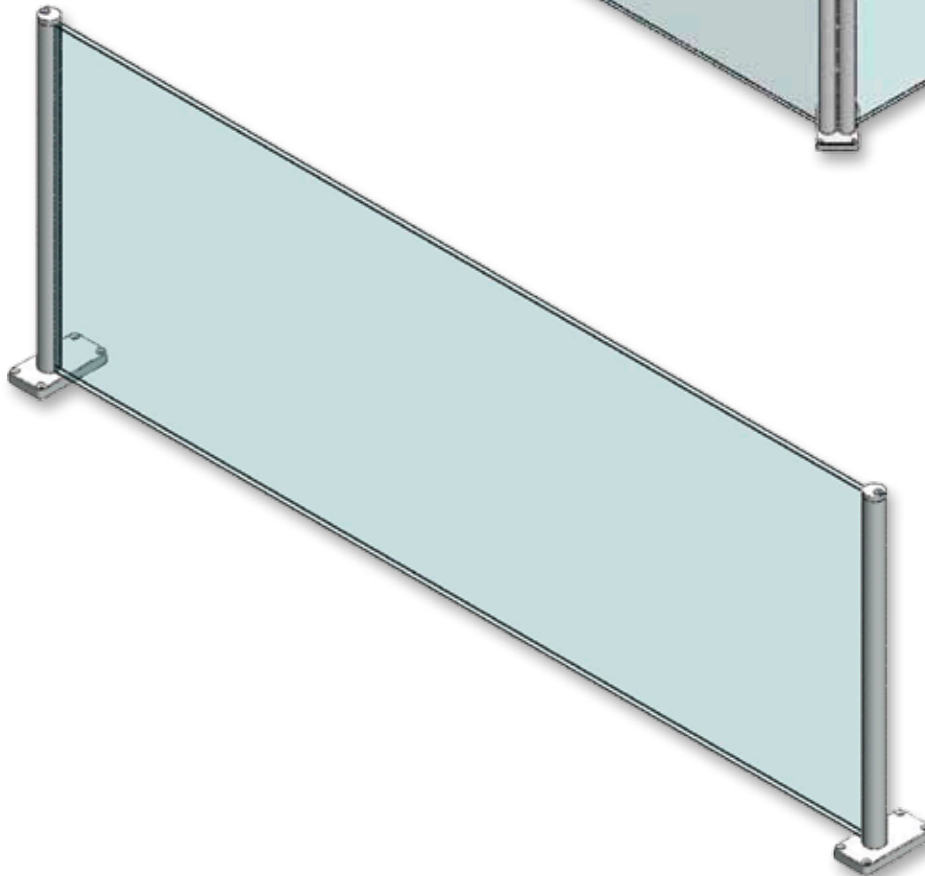

AB-2DV

AMBASSADOR VERTICAL DIVIDER



ANSI/NSF 2

* Images are computer renderings, not actual photos, some color variance may occur from what is rendered to the actual powder coat finish.

Phone: 800-569-2056
Fax: 573-449-7126
www.sneezeguardsolutions.com

SPECIFICATIONS

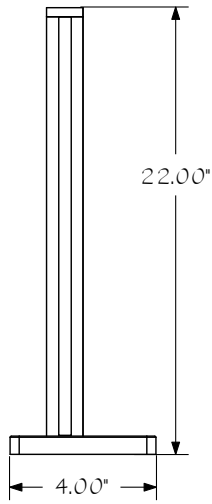

AB-1 DV

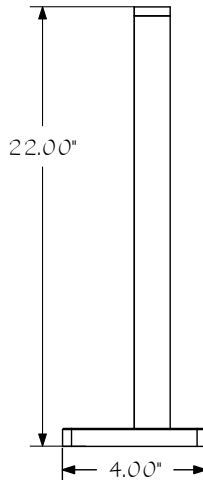

AB-2 DV

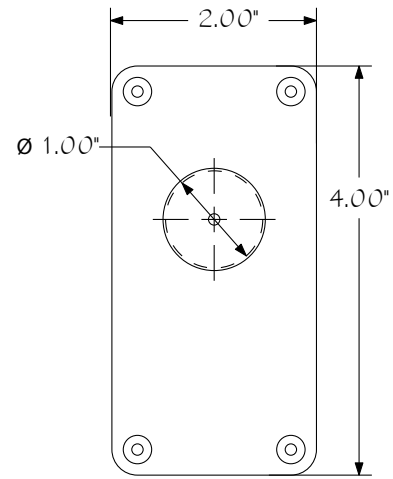

Surface Mount

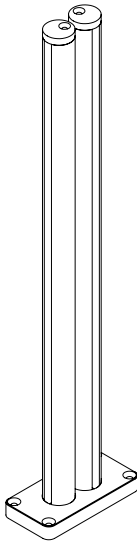

AB-8 DV

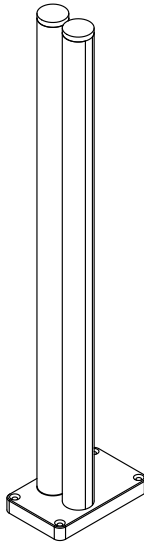

AB-5 DV

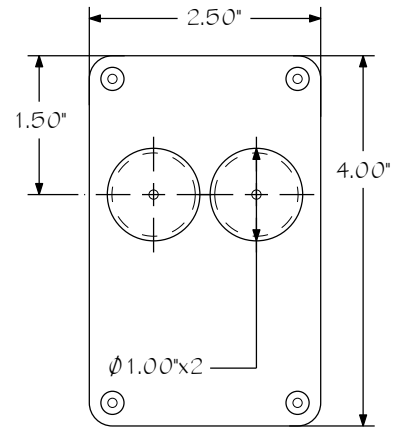

Bridge Surface Mount

AMBASSADOR VERTICAL DIVIDER

<i>Part #</i>	<i>Description</i>	<i>Weight</i>	<i>Color</i>
<i>AB-1 DV</i>	<i>Right frame side</i>	<i>2 lbs</i>	<i>Black</i>
<i>AB-2 DV</i>	<i>Left frame side</i>	<i>2 lbs</i>	<i>Black</i>
<i>AB-5 DV</i>	<i>Center frame</i>	<i>5 lbs</i>	<i>Black</i>
<i>AB-8DV</i>	<i>90° Center frame</i>	<i>5 lbs</i>	<i>Black</i>

Gold and Silver available upon request

Accepts 1/4" tempered glass. Recommended center line spacing is 42" for 1/4" tempered glass.

**Please consult the custom sneeze guard chart before ordering to ensure the proper length of guard needed. If there are any questions concerning the procedure please feel free to call (800) 569-2056 M-Th 8am to 5pm CT and Fri 8am to 3pm CT.*